

# Molteni & C

## D.153.1 ARMCHAIR— GIO PONTI 1953 / 2012

1—  
2



Designed in 1953, the D.153.1 armchair is part of the furniture of Gio Ponti's private house in via Dezza in Milan. This re edition is produced by Molteni&C based on the original drawings from the Ponti archives. Brass structure, cover in bicolor leather or "Punteggiato" fabric, designed by Ponti for Rubelli in 1934. The fabric reinterprets the age-old technique of velvet-weaving, bringing it up to date with contemporary patterns, such as close sequences of staggered disks with various gradations of colour.

### FEATURES

Armchair designed in 1953.

#### DATASHEET

REGISTERED  
DESIGN

XII.2014

**molteni.it**

Dimensions in millimeters and inches. The right to discontinue and make changes is reserved. This information is based on the latest product information available at the time of printing.

**D.153.1**  
**ARMCHAIR** –  
GIO PONTI  
1953 / 2012

## FINISHES

Made with brass frame.

## COVERS

Leather covers: two-coloured combinations: white/blue or sand/paper white.

Fabric covers: Punteggiato Velvet designed by Gio Ponti in 1934, from the Molteni Collection.

The remove of cover must be done by a skilled person.

Available in fire-resistant version (TB117 and BS5852).

# Molteni & C

## TECHNICAL INFORMATION

### UPHOLSTERED STRUCTURE

Frame in solid Fir (Picea abies) with elastic straps, covered in custom polyurethane in different thicknesses.

Bonded velveteen lining.

### ARMREST

In solid Fir covered in custom polyurethane. Bonded velveteen lining.

### LEGS

In heat-sealed steel with a satin brass finish. Feet in non-slip plastic.

### OUTER REMOVABLE COVER

#### Leather

The leather for this article come from bullocks raised in Europe. The selection and treatment of the leather guarantee a "smooth surface", keeping the upper part of the hide mostly unaltered. The carefully chosen leather is tanned (with chrome) and coloured (with aniline dye). All the treatments help to preserve leather's exceptional natural characteristics.

#### Fabric

Ciselè velvet, with its cut and uncut loops, with two thicknesses on a metallic background. (See attached card, specific for each cover).

2—  
2

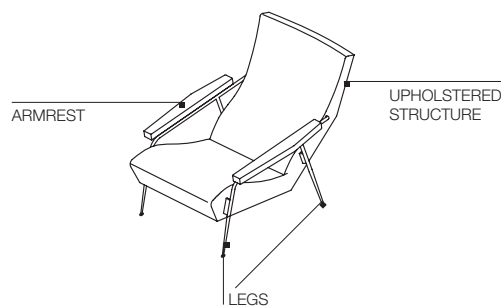

## DIMENSIONS

W 770 D 1030 H 800  
W 30 3/8" D 40 1/2" H 31 1/2"

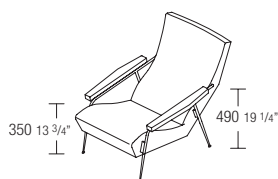

**D.153.1**

## DATASHEET

REGISTERED  
DESIGN

XII.2014

**molteni.it**

Dimensions in millimeters and inches. The right to discontinue and make changes is reserved. This information is based on the latest product information available at the time of printing.