

TRESTLE design John Pawson 2014



With all the usual elegance of Pawson, this bench once again surprises us with its exquisite proportions. Solid oak feet and a subtle seat upholstered in a plain or padded finish in our collection of fabrics and leathers. Ideal both for the home - in its short version - and for waiting areas and hallways in smart public spaces.

TECHNICAL INFO

- 1 - Interior structure in MDF
- 2 - Shape-holding expanded polyurethane foam.
- 3 - Fabric or leather. Finish smooth or padded.
- 4 - Calibrated steel girder lacquered in thermosetting polyester.
- 5 - Legs in solid oak wood.

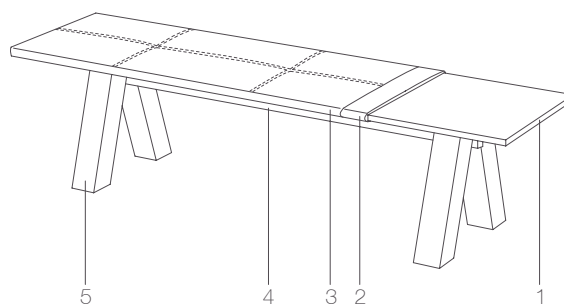

FINISHES

Check upholstery samples.

CERTIFICATES



TRESTLE design John Pawson 2014

PADDED UPHOLSTERY

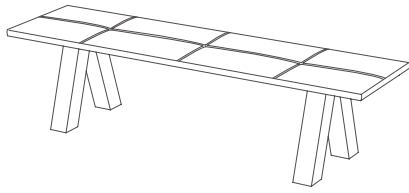

SMOOTH UPHOLSTERY

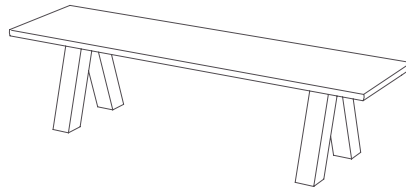

SIMPLE BENCH

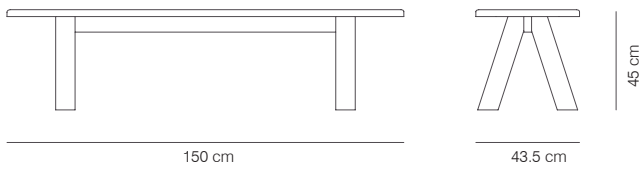

DOUBLE BENCH

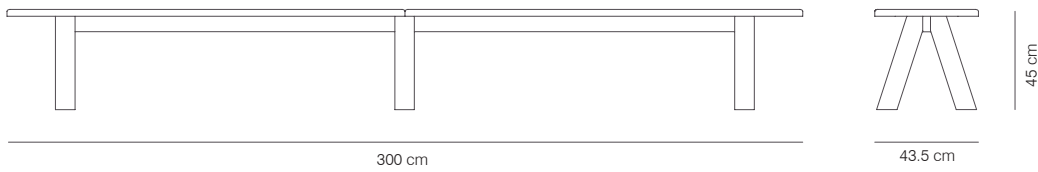

TRIPLE BENCH

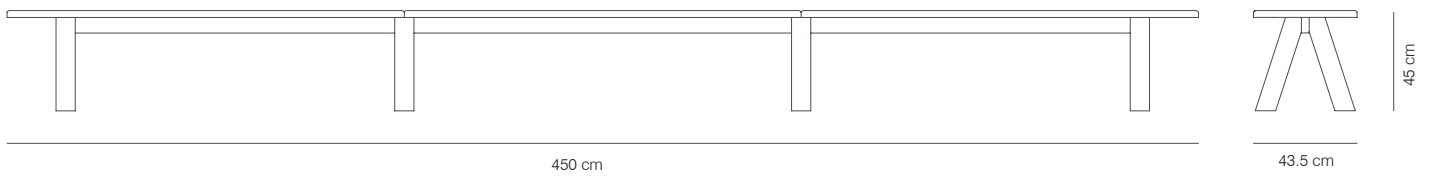

COMPONENTS FOR COMPOSITIONS

LEGS



EXTREME SEAT



CENTRAL SEAT



JOHN PAWSON England



John Pawson was born in 1949 in Halifax, Yorkshire. After a period in the family textile business he lived for a number of years in Japan, moving to Tokyo towards the end of his stay, where he visited the studio of Japanese architect and designer Shiro Kuramata. Following his return to England, he enrolled at the Architecture Association in London, leaving to establish his own practice in 1981.

From the outset Pawson's work has focused on ways of approaching fundamental problems of space, proportion, light and materials - themes he also explored in his book *Minimum*, which examines the notion of simplicity in art, architecture and design across a variety of historical and cultural contexts. Early commissions included homes for the writer Bruce Chatwin, opera director Pierre Audi and collector Doris Lockhart Saatchi, together with art galleries in London, Dublin and New York.

While private houses have remained a consistent strand of the work, subsequent projects have spanned a wide range of scales and typologies, ranging from a bridge across a lake and a flagship store for Calvin Klein, to ballet sets, yacht interiors and a new Cistercian monastery in Bohemia. Pawson is currently working on the remodelling of the former Commonwealth Institute in London, which is scheduled to open as a new permanent home for the Design Museum in 2015.

PRODUCTS

TRESTLE bench